



Fax: 503.253.6564

9" FORD Rear End ORDER FORM

By submitting this form, customer agrees to the current Terms, Conditions, & Policies as stated in the DMI price sheets & web site

SOLD / BILL TO: SHIP TO: Name, Company, Address, City, State, Zip, DAY PHONE, EVE PHONE, FAX, Email

9" Housing Style / Description: Roadster Round Back, HD Street & Strip, D-Fab 9, Polished Aluminum, Options: Axle shaft material, Wheel bearings, Access Holes, Extra bolt pattern, Install drain, Install econo filler, Install deluxe filler, Install back brace, Back brace loose, Powder coat, Brake line tabs

Brake Kits & Options: DMI drum kit, Wilwood disc kit, Right Stuff disc kit, Manufacturers name & Part #, Brake offset, Center hole in the drum or rotor, Flange OD, Housing end your brake kit was designed for, Small Ford, Big Ford-Old, Big Ford-New, If other, List style or dimensions

Vehicle: Engine: Tranny: Stall: Trans Brake, Blower, Nitrous, HP, Torque, Ratio, Street, Strip, Roadrace/autocross/circle track, Offroad, Show only, Non performance cruiser, Mild perf, Hi perf

Office use only: \$ Advance: Rec#, Cash, Check, Money Order, Cashiers / Certified, Salesman: PP#

Name: _____

Date: _____

Attn: _____

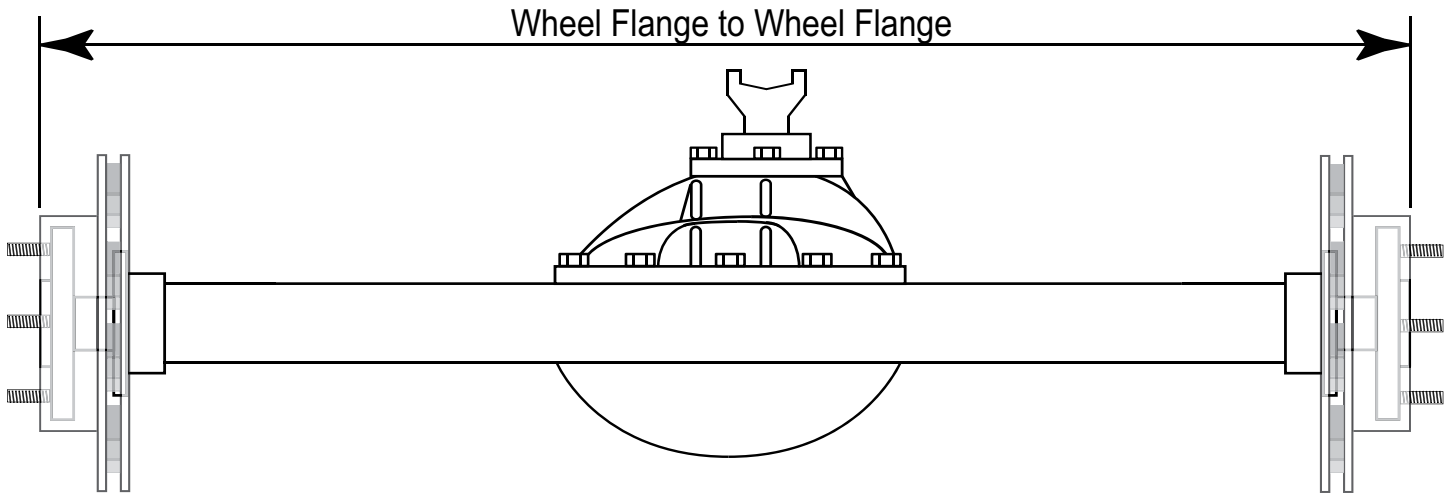

Desired width: _____

-This is to the wheel mounting faces & includes the thickness of the drums or rotors.

Centered Pinion Centered Housing Other _____

Bolt pattern(s): _____ studs on a _____ diameter bolt circle.

-Optional 2nd pattern: _____ studs on a _____ diameter bolt circle.

Studs: 7/16" 1/2" 5/8" Metric _____ mm x _____ pitch

-Length: Stock Length - press in Extra Long - screw in (1/2" only)
 2" 3"

Brackets:

- None - Customer doing own
- Customer supplied
- Dutchman supplied

- Brackets installed
- Brackets loose
- Brackets slid on tubes - left loose
- Cut-N-Call

- *Leaf spring vehicle
 - 2" 2 1/2"
 - GM Mono leaf GM Multi leaf
 - Under Top of Housing

- *Coil spring vehicle

*List year, make, and model below, ie. 70 GM Chevelle, 65 Ford Mustang, 59 Chevy Impala, etc...

*Aftermarket 4 link
Brand _____

*Bracket center to center _____

*Pinion angle _____

*Leaf spring & AM 4 link only

Notes _____

Customer ok: _____

3rd member:

-If you're *not* ordering a 3rd member, how many splines does yours have? _____

- Street
 - Open Diff Trac Loc
 - Tru Trac Detroit Locker

- Street Plus
 - Open Diff Trac Loc
 - Tru Trac Detroit Locker

- Pro Street
 - Tru Trac Trac Loc
 - Detroit Locker Lenco Locker

Full Race [Full spool]

- Street Aluminum
 - Plain Polished
 - Open Diff Trac Loc
 - Tru Trac Detroit Locker

- Pro Aluminum [Thru Bolt case]
 - Plain Polished
 - Trac Loc Tru Trac D. Locker

Ratio: _____ Splines: _____

Pinion Support: Nodular Forged Alum.

Yoke: Forged 1350 Chromoly

Powder coat: Semi-flat Black Other

*Premium gear upgrade

*Aftermarket gears may make noise

Big Ford-New Style

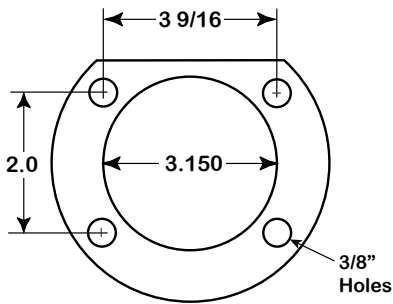

Big Ford-Old Style

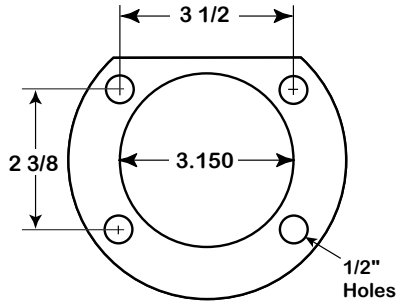

Small Ford

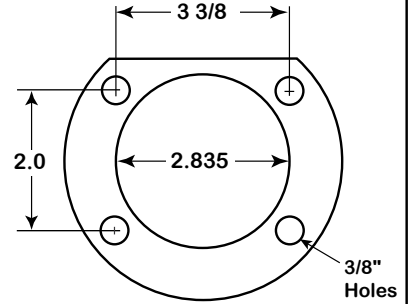

Mopar 8 3/4

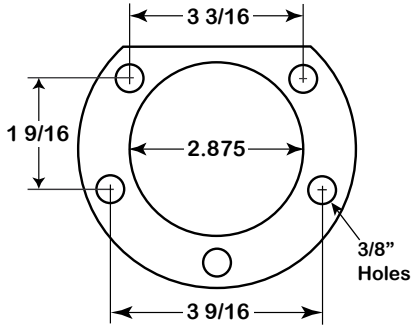

57-64 Olds/Pontiac

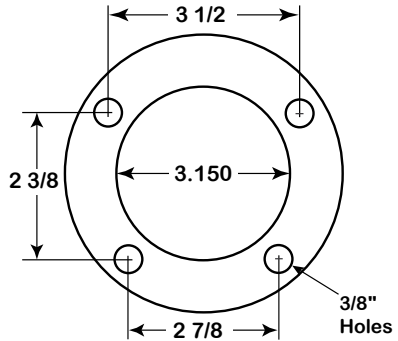

64 & up Buick/Olds/Pontiac

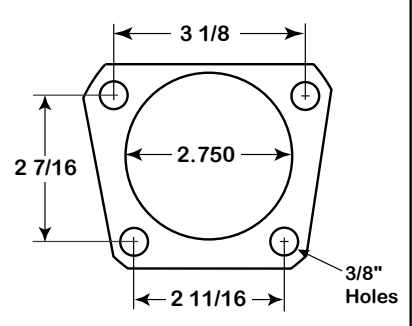

TJ

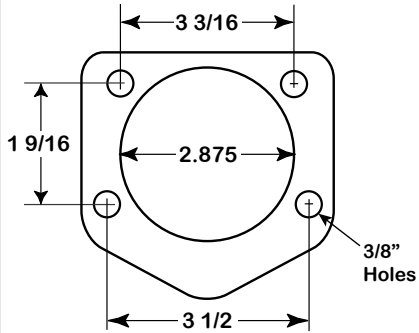

Jeep CJ

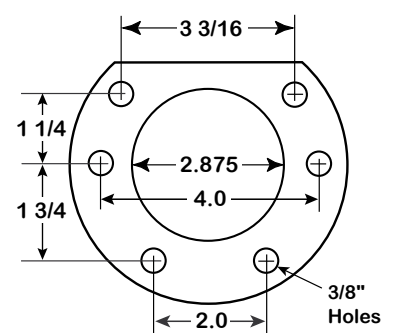

Wagoneer / YJ

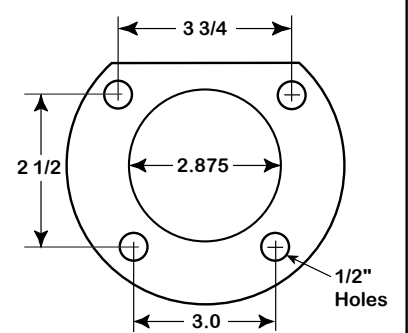

55-56 Chevy Belair

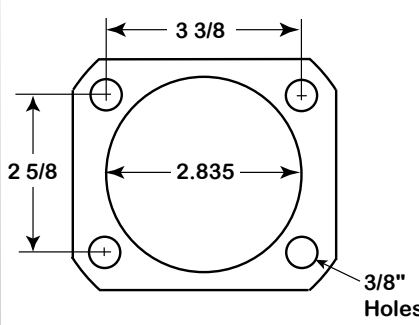

57-64 Chevy Belair/Impala

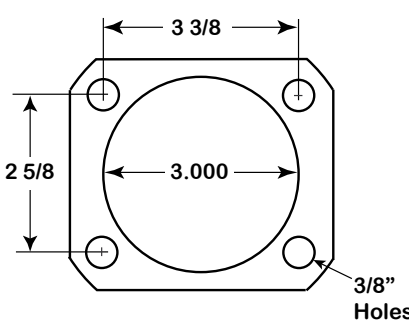

Wagoneer

